

INSTRUMENT PANEL CLUSTER (IPC) REPLACEMENT

REMOVAL PROCEDURE

- 1 Remove the instrument panel (I/P) cluster trim plate bezel.

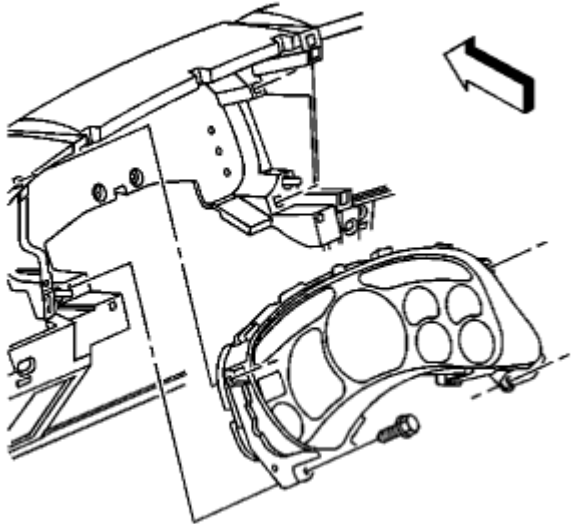

- 2 Remove the screws that retain the I/P cluster to the I/P assembly.

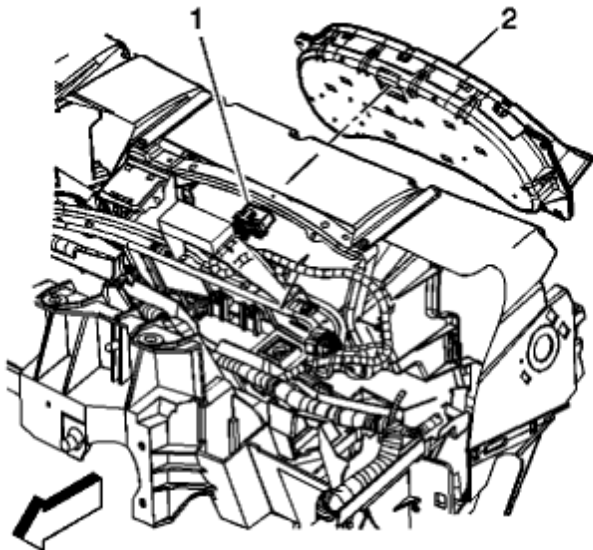

- 3 Remove the I/P cluster (2) from the vehicle by tilting the bottom of the cluster outward.
- 4 Disconnect the I/P cluster harness (1) from the I/P cluster.

INSTALLATION PROCEDURE

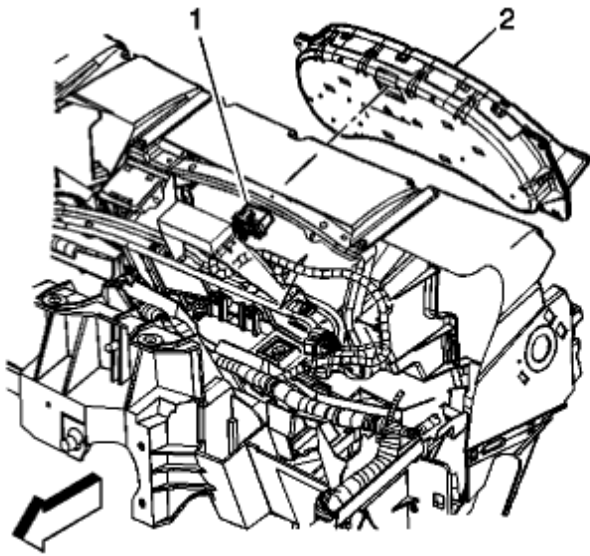

- 1 Connect the I/P cluster harness (1) to the I/P cluster (2).

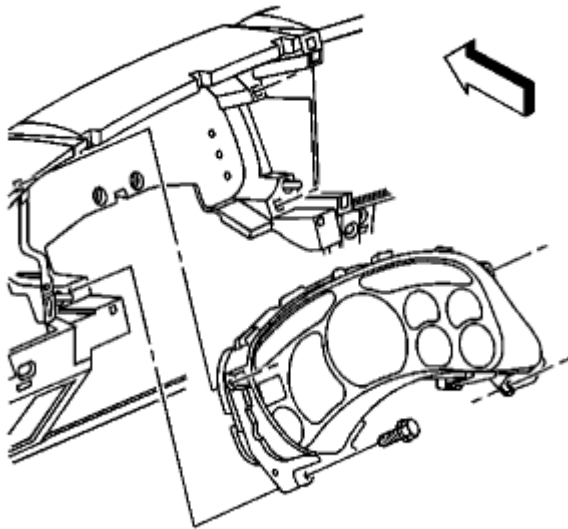

- 2 Install the I/P cluster onto the I/P with the screws. Tilt the top of the cluster into the retainer first to avoid damaging the flexible circuit connections.
- 3 Install the screws that retain the I/P cluster to the I/P assembly.